

# RAIN-TIGHT FIL-SPIL CONTAINMENT BOXES

## SPECIFICATIONS:

- \***SKIRT:** 14 GAUGE GALVANIZED SHEET METAL.
- \***COVER:** 3/8" REINFORCED FLOOR PLATE, COMPLIES WITH H2O RATING.
- \***GASKET:** LOW SWELL H.N.B.
- \***REINFORCING:** 14 GAUGE SHEET METAL.

## FEATURES:

- \* 7/8" FINGER HOLE ON "12 BOXES, UPON REQUEST.
- \* LIFT HANDLE ON ALL BOXES 24" AND LARGER.
- \* TAMPER PROOF ALLEN SCREWS ARE AVAILABLE AS AN OPTION.
- \* 1 1/4" WIDE LIP FOR COVER SUPPORT.
- \* MANHOLES SHIPPED ASSEMBLED.
- \* BOXES HAVE 4 FLANGES WELDED TO THE SKIRT TO INSERT A PIECE OF #4 RE-BAR, TO ANCHOR BOX TO CONCRETE.

## SQUARE ECONOMY MANHOLES

(SCREWS AND GASKETS)		
REINFORCED	WITH	WITHOUT
SIZE	WATER-TIGHT	STANDARD
12" X 24" X 9"	9003	9001
24" X 24" X 9"	9008	9007
30" X 30" X 9"	9013	9012
36" X 36" X 9"	9018	9017
48" X 48" X 9"	9023	9022
42" X 42" X 9"	9024	----

OPTION: C = CAM LOK

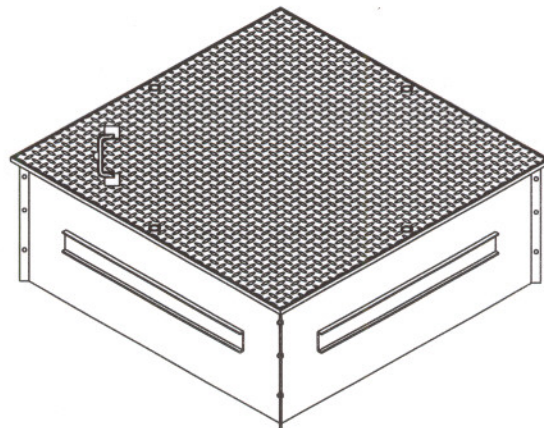

ITEMS WITH SCREWS AND GASKETS ARE WATERTIGHT  
SPECIAL SIZES AVAILABLE UPON REQUEST

## SPECIFICATIONS:

- \***SKIRT:** 14 GAUGE GALVANIZED METAL
- \***COVER:** 3/8" FLOOR PLATE COMPLIES WITH H2O RATING
- \***GASKET:** LOW SWELL H.N.B.
- \***BOLT DOWN:** 3/8" HEX BOLT LOCK DOWN
- \***24", 30" and 37" - 4 BOLTS**
- \***42" - 6 BOLTS**
- \***48" - 8 BOLTS**

## OPTIONS:

- ADD LETTER "C" FOR CAM-LOK
- ADD LETTERS "OOCL7" FOR 7" OBSERVATION PORT
- ADD LETTERS "OOCL12" FOR 12" OBSERVATION PORT

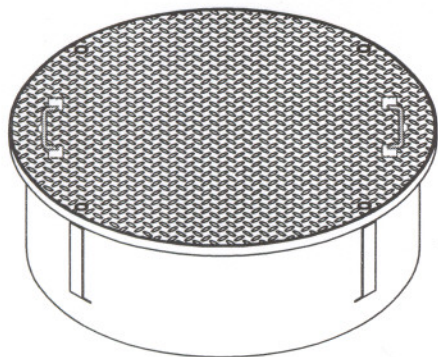

# UL LISTED!

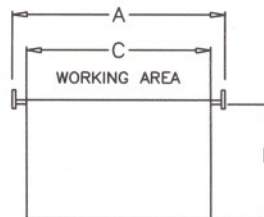

## MANHOLE DIMENSIONS

SIZE	DIM "A"	DIM "C"	DIM "D"	REINFD.
12"	12 1/4"	9 1/4"	12"	YES
16"	16 3/4"	13 3/4"	12"	YES
18"	18"	15"	12"	YES
24"	24 5/16"	21 1/8"	12"	YES
30"	31 5/8"	28 5/16"	12"	YES
37"	37 5/8"	34 5/16"	12"	YES
42"	43"	39 3/4"	12"	YES
49"	49 1/2"	46 1/4"	12"	YES

## ROUND ECONOMY MANHOLES ROLLED STEEL RINGS W/12" SKIRTS

NOTE: (SCREWS AND GASKETS)  
12", 16" & 18" have 10" SKIRTS

WITH			WITHOUT		
ONE LIFT HANDLE	WATER-TIGHT	STANDARD	ONE LIFT HANDLE	WATER-TIGHT	STANDARD
12"	8011	-----	12"	8011	-----
16"	8020	-----	16"	8020	-----
18"	8029	-----	18"	8029	-----
24"	8034	8033	24"	8034	8033
30"	8039	8038	30"	8039	8038
TWO LIFT HANDLE			TWO LIFT HANDLE		
ONE LIFT HANDLE	WATER-TIGHT	STANDARD	ONE LIFT HANDLE	WATER-TIGHT	STANDARD
37"	8044	8043	37"	8044	8043
43"	8049	8048	43"	8049	8048
49"	8054	8053	49"	8054	8053

OPTION: C = CAM LOK

## NOTE: CAM-LOK REQUIREMENTS

- 24" & 30"      4 CAM-LOK
- 37"            5 CAM-LOK
- 43"            6 CAM-LOK
- 49"            7 CAM-LOK